



## QUATTRO 25mm SNAPSEAM

---

Steelformers Quattro 25mm Snapseam is an architectural style roofing and cladding system, with thick distinctive ribs and wide pans giving it visual appeal. This profile provides a similar but slightly bolder look to Double Standing Seam but differs in that the panels snap together to form a locking joint, rather than requiring crimping. The Quattro 25mm Snapseam pan width can be increased or decreased to suit between windows and doorways so that the ribs finish neatly.

### SCOPE OF USE

---

Suitable for residential, light commercial and commercial roofing and cladding applications.

### AVAILABLE IN A RANGE OF MATERIALS

---

Available in 0.55mm (G300) BMT Colorsteel Maxam®, Colorsteel Altimate®, 0.75mm BMT Copper, 0.90mm BMT Mill Finish Aluminium and ColorCote® Alumigard™ (available on request, conditions apply).

### SHEET LENGTHS

---

Sheet lengths are custom run to order. Sheet length restrictions may apply depending on project location.

### PITCH

---

In accordance with E2/AS1, the minimum pitch is 3°

### PANS AND SWAGES

---

The standard pan widths (from rib to rib) are 195mm (wall cladding only), 275mm and 415mm. The pans are variable on request.

It is mandatory practice that the pans are run with swages. The swages are discreet and provide for extra rigidity and strength, as well as assisting in the reduction of oil canning. If the customer wants the pans run without swages, it will be at the discretion of Steelformers (on a case by case basis).

### TECHNICAL SUPPORT

---

Contact a Steelformers representative at your local branch for detailed technical advice. A range of flashing details are available for download on our website.

## SPECIFICATIONS

---

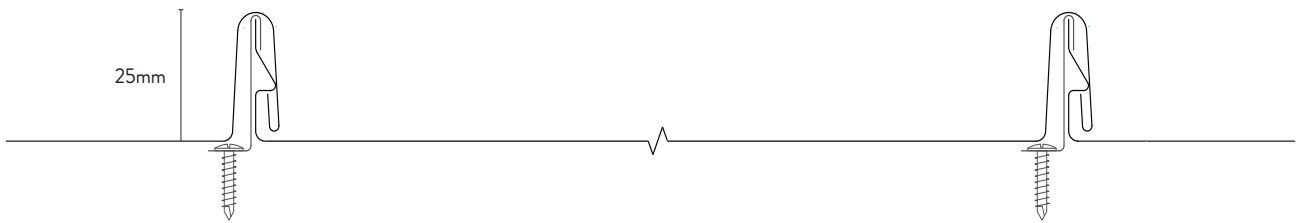

## ROOFING APPLICATIONS

---

Quattro 25mm Snapseam roofing is installed over a solid plywood substrate with purlin supports.

The purlin supports are generally:

- 75 x 50mm or 100 x 50mm purlins on the flat, fixed in accordance with the New Zealand Building Code.

The required plywood substrate must be:

- A minimum 12mm thick plywood sheet, structurally fixed to the frame in accordance with the New Zealand Building Code
- Fixed with 8g x 40mm countersunk stainless steel screws at 150mm centres around each panel edge and 300mm centres on the intermediate supports. The fasteners should be no closer than 10mm to the edge
- H3.2 treated (using a water based system) and of Stress Grade F11, with a moisture content of 18% or less at the time of installation
- A 2-3mm expansion gap between sheets should be provided. All joints should be staggered, whilst ensuring all edges of the sheets are fully supported. This allows added air-flow between the underside of the tray and the substrate
- At the gutter line plywood should overhang the fascia board by 25mm

## FIXING PATTERN

---

Maximum 450mm purlin centres with min. 12mm ply substrate

Clips fixed at 450mm centres

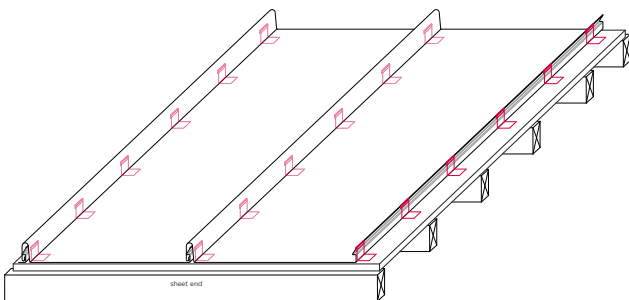

*In all wind zones, it is Steelformers standard practice that the clips are to be fixed to all ribs of all purlin lines (or nog lines for wall applications).*

## WALL CLADDING

---

Quattro 25mm Snapseam cladding is installed over a solid cavity system (make reference to E2 and the New Zealand Building Code for cavity requirements). In unlined areas, a cavity system is not required. Steelformers recommends nog spacing at 600mm centres in all wind zones, plus having a row of fixings along the line of the top and bottom of the cladding panel. Depending on the eaves construction, a row of nogs may be required at the eaves soffit line to fix into.

## CLIP FIXING

---

Concealed clips hook over the small rib of the sheet and are then fastened directly into the purlin or substrate. The larger rib on the preceding roof sheet is then snapped and locked down over the small rib and clipped. The edges of the sheets should be fixed for strength and spanning capability, and each clip must have a minimum of two fixings.

Purlin or frame material	Roof (no substrate)	Roof (ply substrate)	Wall (over cavity batten)
Timber	Class 4 Type 17 10g x 45mm	Class 4 Type 17 10g x 65mm	Class 4 Type 17 10g x 65mm
Steel	Class 4 10g x 16mm	Class 4 10g x 40mm	Class 4 10g x 40mm

The fasteners must be long enough to pass through the purlin or cavity batten and into the main frame by 30mm for timber and 6mm for steel. Ensure the fastener is fixed in the centre of the opening to allow for thermal expansion and contraction.

*Reference should be made to the NZ MRM Code of Practice, E2/AS1 and the New Zealand Building Code. In some cases (for example, SED wind zones) increased support spacing and fixing may be required.*

## BRANCHES

---

Taranaki Steelformers Ltd  
Mountain Road, Stratford 4332  
P. 0800 655 142 or 06 765 5191  
F. 06 765 8185  
E. stratfordoffice@steelformers.co.nz

Wanganui Steelformers  
380 Heads Road, Wanganui 4501  
P. 0800 800 077 or 06 344 5142  
F. 06 344 6766  
E. chris@steelformers.co.nz  
sara@steelformers.co.nz

Taranaki Steelformers Ltd  
23 Katere Road, Waiwakaiho, New Plymouth 4312  
P. 0800 476 634 or 06 758 3831  
F. 06 758 5784  
E. npoffice@steelformers.co.nz

King Country Longrun  
Huia Street, Taumarunui 3920  
P. 07 895 6464  
F. 07 895 6858  
E. blair@steelformers.co.nz

For more information on Steelform Roofing Group and their range of products head to [www.steelformers.co.nz](http://www.steelformers.co.nz). For detailed technical advice, contact your nearest Steelformers branch or visit Steelformers product section at [masterspec.co.nz](http://masterspec.co.nz).



## DISCLAIMER

---

Because of Steelform Roofing Groups' policy of continuous product improvement the company reserves the right, at any time and without notice to discontinue or modify designs, features and other specifications of their product. Steelform Roofing Group disclaim any liability for loss or damage suffered from the use of such material as all information is correct to the best of our knowledge at the time of publishing. This document is issued as a guide only and should not be substituted for detailed technical advice.

V3 | August 2024

